

Assembly Instructions - WBC Brood Chamber

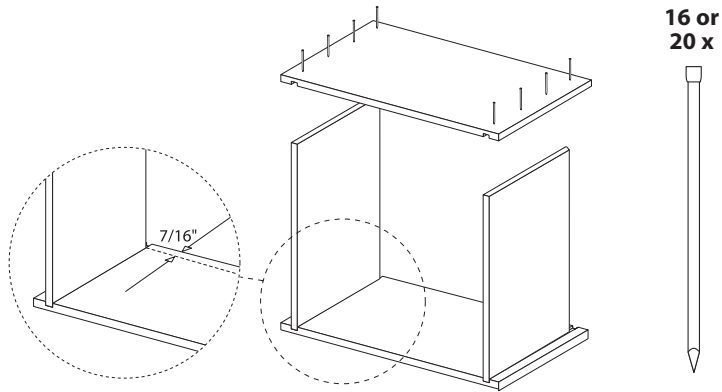

MAISEMORE APIARIES



1

Lay side panel flat. Insert support panels chamfer sloping down and outwards into rebates. The top edge must be 7/16" below the top edge of the side panel. Nail side panels to support boards using 16 x 40 mm lost head nails, (20 nails if making a 14 x 12 chamber)

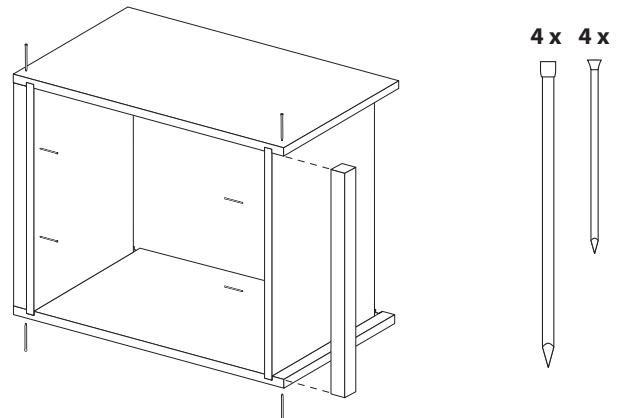

2

Place side blocks in position, flush to corners as shown and nail in position using 4 x 25 mm pins and 4 x 40 mm lost head nails

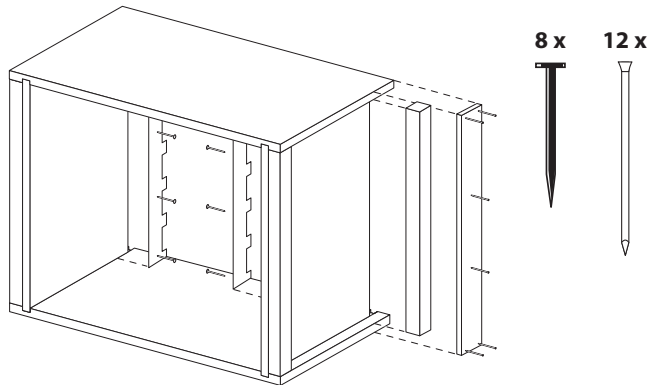

3

Fit second pair of blocks between side panels and nail side strips to side panels, flush to top edge of side panels, using 12 x 25 mm pins. Fit Frame Separators to inside of side panels as shown, using 8 x 19mm frame nails.

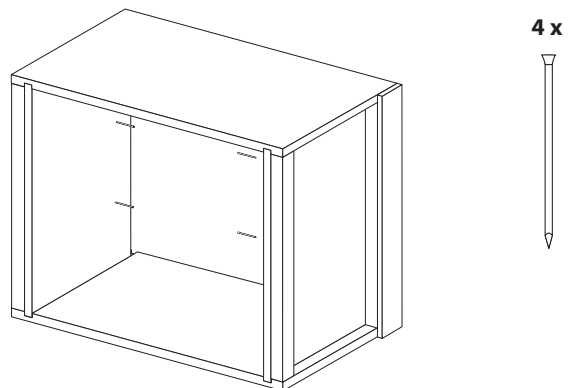

4

Nail through side panels into side blocks using 4 x 25 mm pins, ensuring side blocks remain flush with lower edge of side strip.

Old Road, Maisemore, Gloucester, GL2 8HT Tel: 01452 700289 Fax: 01452 700196 email: sales@bees-online.co.uk www.bees-online.co.uk www.honey-online.co.uk

Assembly Instructions - WBC Brood Chamber



MAISEMORE APIARIES

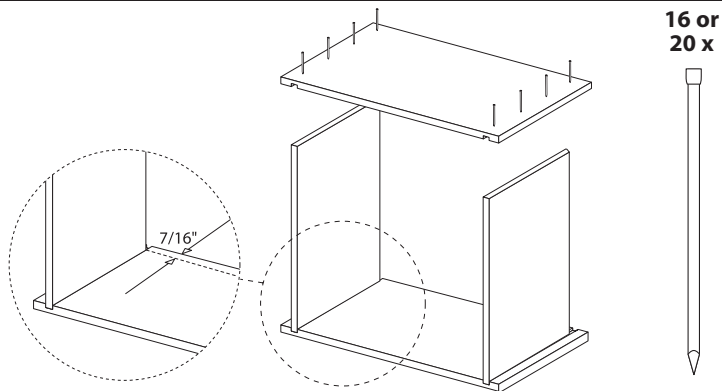

1

Lay side panel flat. Insert support panels chamfer sloping down and outwards into rebates. The top edge must be 7/16" below the top edge of the side panel. Nail side panels to support boards using 16 x 40 mm lost head nails, (20 nails if making a 14 x 12 chamber)

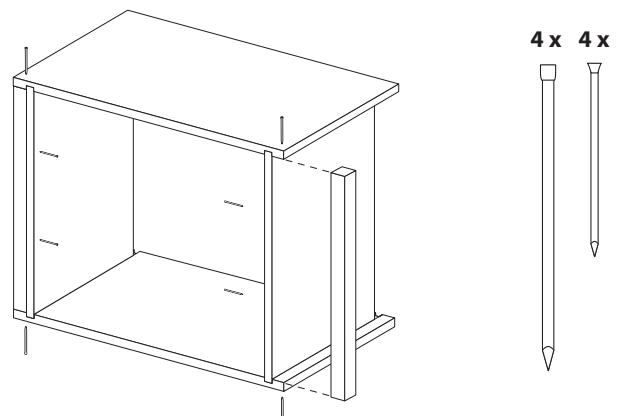

2

Place side blocks in position, flush to corners as shown and nail in position using 4 x 25 mm pins and 4 x 40 mm lost head nails

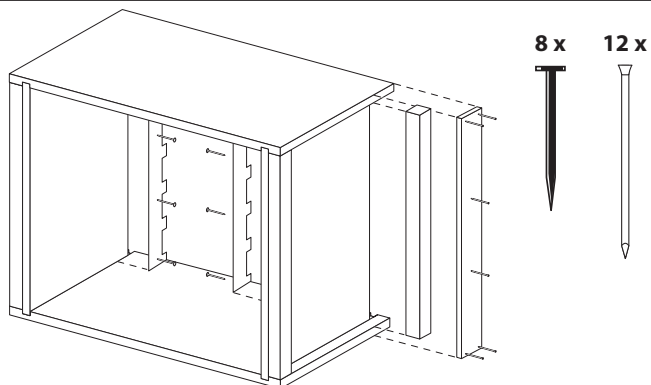

3

Fit second pair of blocks between side panels and nail side strips to side panels, flush to top edge of side panels, using 12 x 25 mm pins. Fit Frame Separators to inside of side panels as shown, using 8 x 19mm frame nails.

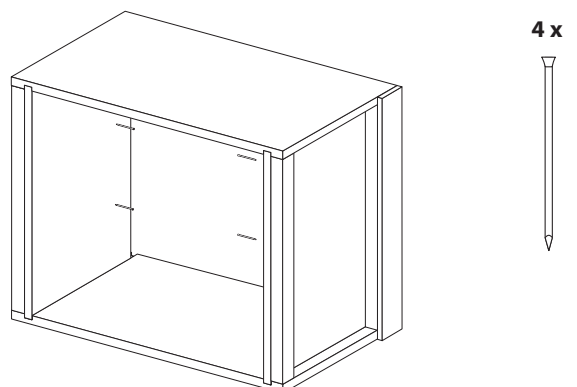

4

Nail through side panels into side blocks using 4 x 25 mm pins, ensuring side blocks remain flush with lower edge of side strip.

Old Road, Maisemore, Gloucester, GL2 8HT Tel: 01452 700289 Fax: 01452 700196 email: sales@bees-online.co.uk www.bees-online.co.uk www.honey-online.co.uk

Assembly Instructions - WBC Super



MAISEMORE APIARIES

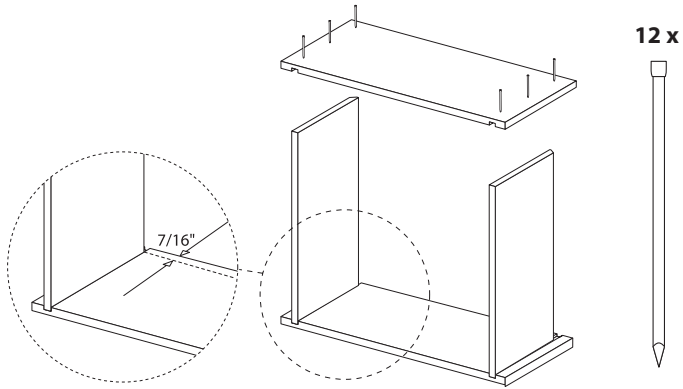

12 x



1

Lay side panel flat. Insert support panels chamfer sloping down and outwards into rebates. The top edge must be 7/16" below the top edge of the side panel. Nail side panels to support boards using 12 x 40 mm lost head nails

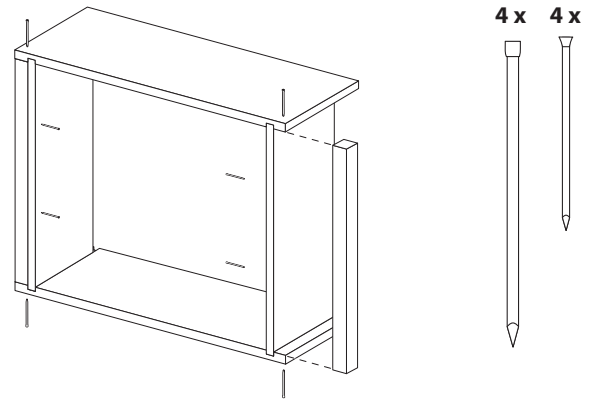

4 x 4 x

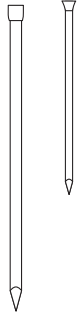

2

Place side blocks in position, flush to corners as shown and nail in position using 4 x 25mm pins and 4 x 40 mm lost head nails

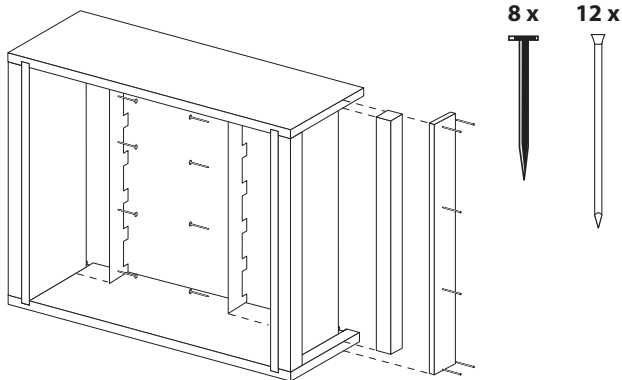

8 x 12 x



3

Fit second pair of blocks between side panels and nail side strips to side panels, flush to top edge of side panels, using 12 x 25 mm pins. Fit Frame Separators to inside of side panels as shown, using 8 x 19mm frame nails.

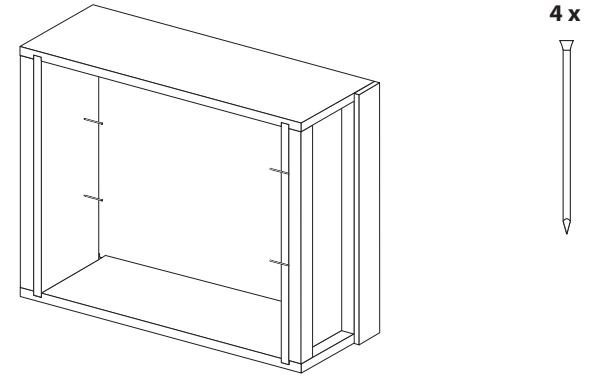

4 x



4

Nail through side panels into side blocks using 4 x 25 mm pins, ensuring side blocks remain flush with lower edge of side strip.

Old Road, MaiseMore, Gloucester, GL2 8HT Tel: 01452 700289 Fax: 01452 700196 email: sales@bees-online.co.uk www.bees-online.co.uk www.honey-online.co.uk

Assembly Instructions - WBC Super



MAISEMORE APIARIES

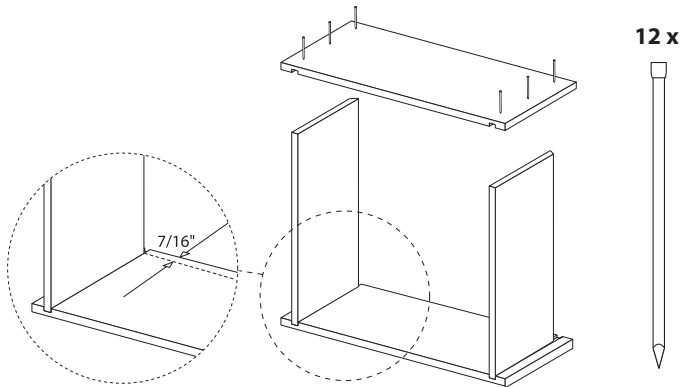

12 x



1

Lay side panel flat. Insert support panels chamfer sloping down and outwards into rebates. The top edge must be 7/16" below the top edge of the side panel. Nail side panels to support boards using 12 x 40 mm lost head nails

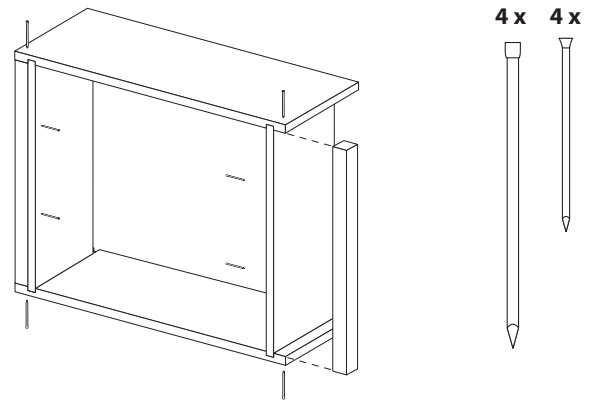

4 x 4 x

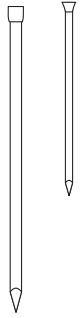

2

Place side blocks in position, flush to corners as shown and nail in position using 4 x 25mm pins and 4 x 40 mm lost head nails

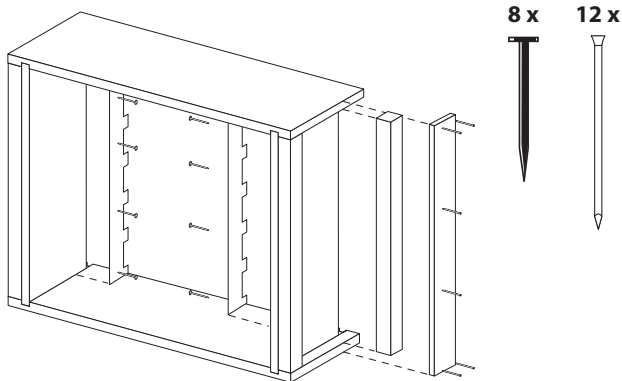

8 x 12 x



3

Fit second pair of blocks between side panels and nail side strips to side panels, flush to top edge of side panels, using 12 x 25 mm pins. Fit Frame Separators to inside of side panels as shown, using 8 x 19mm frame nails.

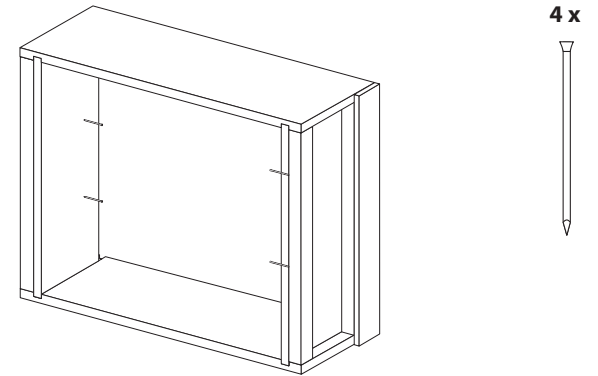

4 x



4

Nail through side panels into side blocks using 4 x 25 mm pins, ensuring side blocks remain flush with lower edge of side strip.

Old Road, MaiseMore, Gloucester, GL2 8HT Tel: 01452 700289 Fax: 01452 700196 email: sales@bees-online.co.uk www.bees-online.co.uk www.honey-online.co.uk

Assembly Instructions - WBC Floor



MAISEMORE APIARIES

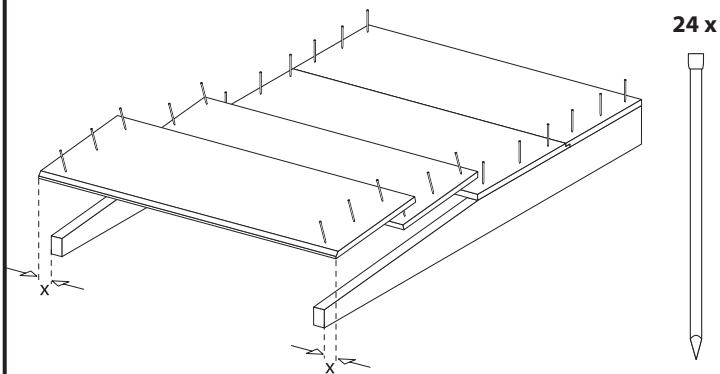

24 x



1

Place floor rails as shown. Nail floor panels to rails using 6 x 40 mm lost head nails per board. Note: The two panels with rebate edge joint go to the rear and the longer panel to the front, chamfer forward, projecting equally on both sides.

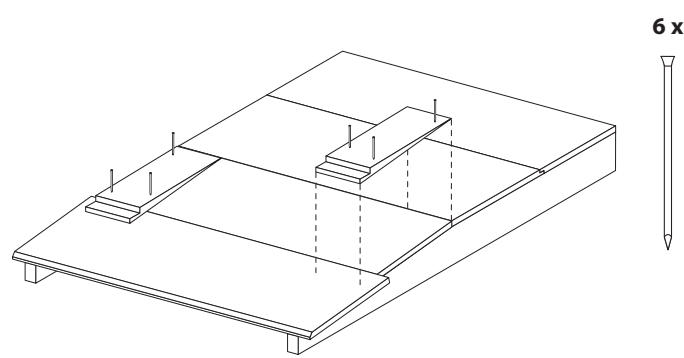

6 x



2

Position support wedges as shown, Note: Top of wedge should be level with flat area of floor. Nail support wedges to floor using 6 x 25 mm pins.

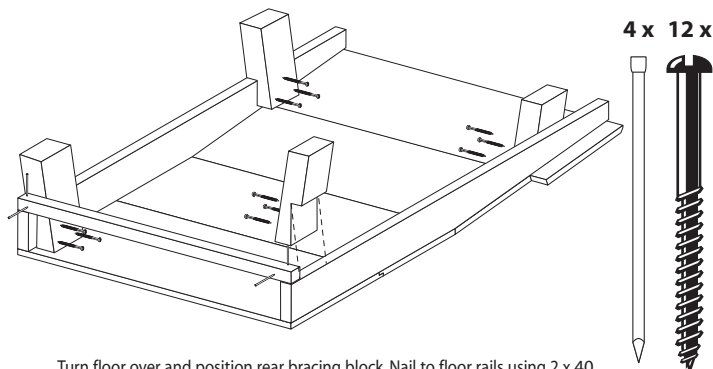

4 x 12 x

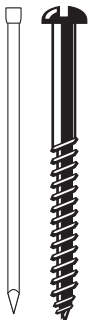

3

Turn floor over and position rear bracing block. Nail to floor rails using 2 x 40 mm lost head nails. Position rear legs (Note: Rear legs are longer) and fix using 6 x 40mm black Japanned screws. Nail block to rear legs using 2 x 40 mm lost head nails. Slide front legs forward until they touch underside of floor panels and fix using 6 x 40 mm black Japanned screws.

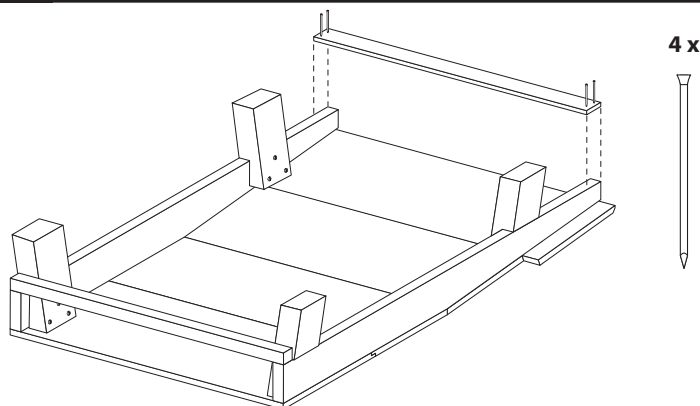

4 x



4

Position front bracing strip as shown and nail into position using 4 x 25 mm pins.

Old Road, Maisemore, Gloucester, GL2 8HT Tel: 01452 700289 Fax: 01452 700196 email: sales@bees-online.co.uk www.bees-online.co.uk www.honey-online.co.uk

Assembly Instructions - WBC Floor



MAISEMORE APIARIES

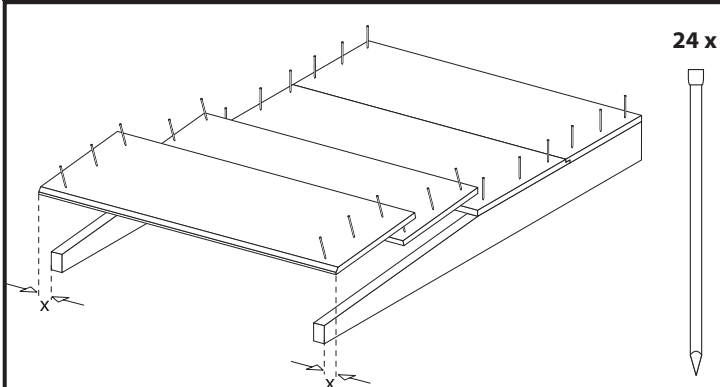

24 x



1

Place floor rails as shown. Nail floor panels to rails using 6 x 40 mm lost head nails per board. Note: The two panels with rebate edge joint go to the rear and the longer panel to the front, chamfer forward, projecting equally on both sides.

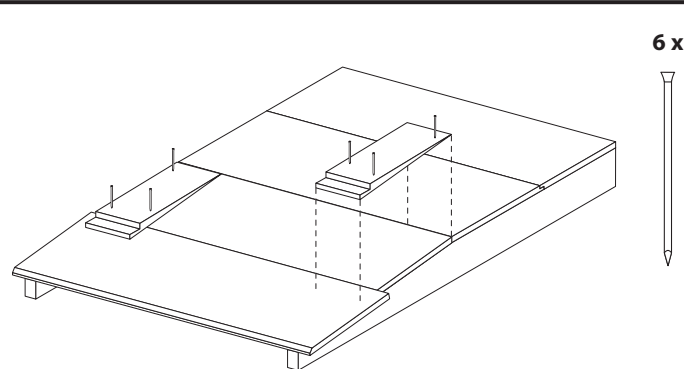

6 x



2

Position support wedges as shown, Note: Top of wedge should be level with flat area of floor. Nail support wedges to floor using 6 x 25 mm pins.

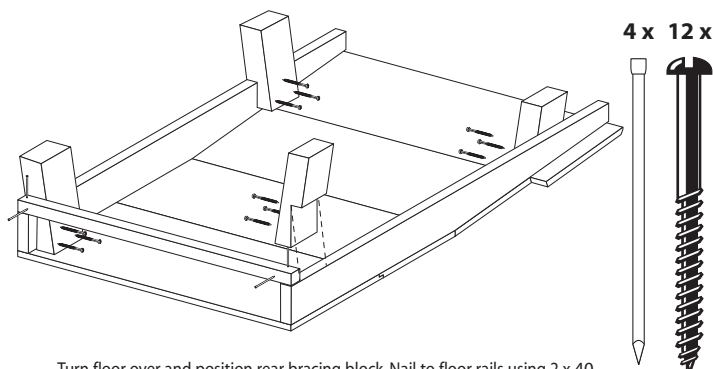

4 x 12 x

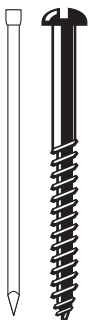

3

Turn floor over and position rear bracing block. Nail to floor rails using 2 x 40 mm lost head nails. Position rear legs (Note: Rear legs are longer) and fix using 6 x 40mm black Japanned screws. Nail block to rear legs using 2 x 40 mm lost head nails. Slide front legs forward until they touch underside of floor panels and fix using 6 x 40 mm black Japanned screws.

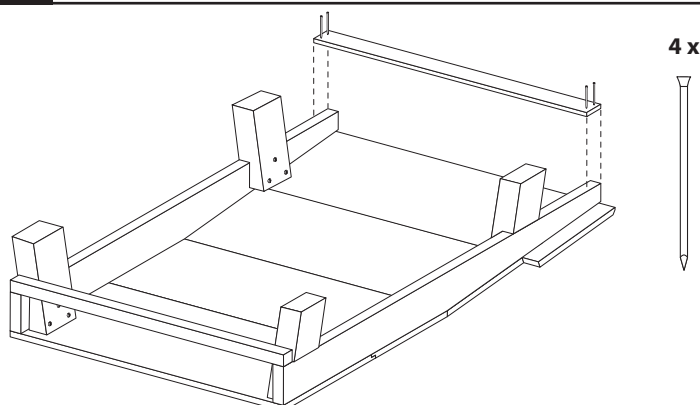

4 x



4

Position front bracing strip as shown and nail into position using 4 x 25 mm pins.

Old Road, Maisemore, Gloucester, GL2 8HT Tel: 01452 700289 Fax: 01452 700196 email: sales@bees-online.co.uk www.bees-online.co.uk www.honey-online.co.uk

Assembly Instructions - WBC Roof



MAISEMORE APIARIES

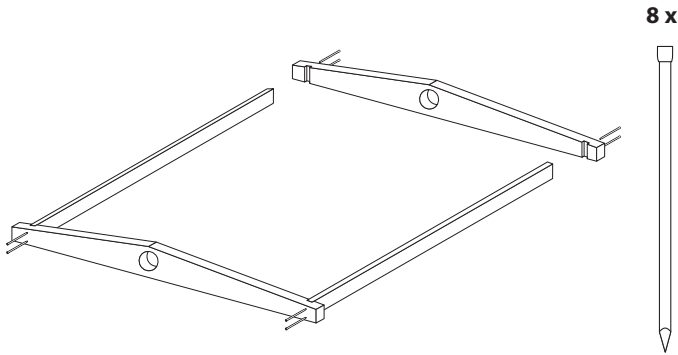

1 Assemble roof ends to side rails sides as shown. Nail through ends into side rails using 8 x 40 mm lost head nails. Check assembly remains square.

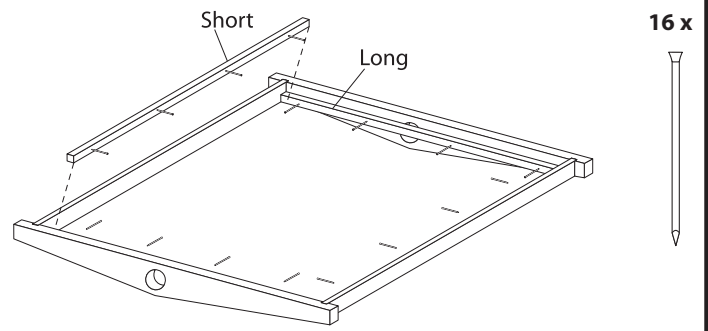

2 Turn roof over and position inner end strips (longer). Nail to ends using 4 x 25 mm pins. Position inner side strips (shorter). Nail to sides using 4 x 25 mm pins.

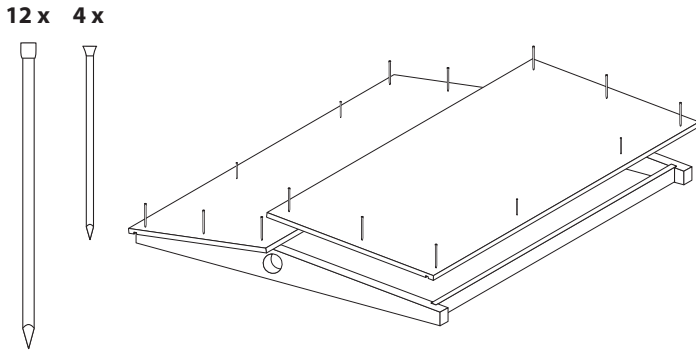

3 Position roof panels as shown (overhang equally at each end) and nail to end boards using 12 x 40 mm lost head nails. Nail to sides using 4 x 25 mm pins.

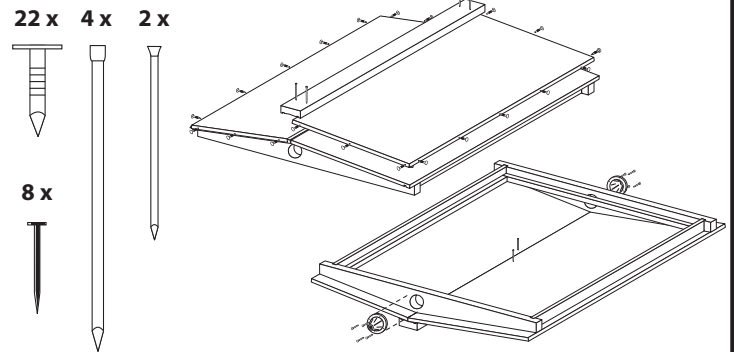

4 Turn roof over, place metal covers over roof and nail to roof edges using 22 x 12 mm round head nails. Position apex cover strip as shown and nail to roof end boards using 4 x 40 mm lost head nails. Turn roof over and nail through roof panels into apex cover strip using 2 x 25 mm pins. Position vent covers over vent holes and nail in place using 8 x 12 mm black japanned round head tacks.

Old Road, Maisemore, Gloucester, GL2 8HT Tel: 01452 700289 Fax: 01452 700196 email: sales@bees-online.co.uk www.bees-online.co.uk www.honey-online.co.uk

Assembly Instructions - WBC Roof



MAISEMORE APIARIES

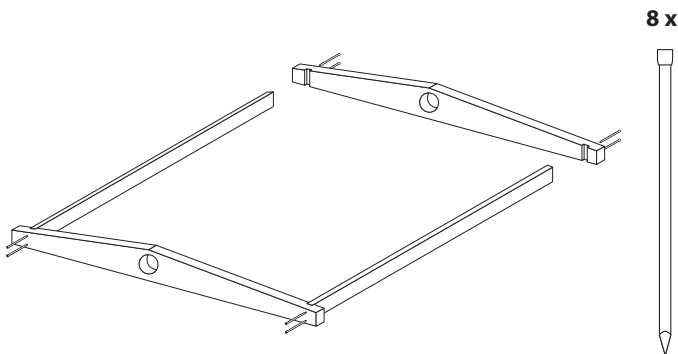

1 Assemble roof ends to side rails sides as shown. Nail through ends into side rails using 8 x 40 mm lost head nails. Check assembly remains square.

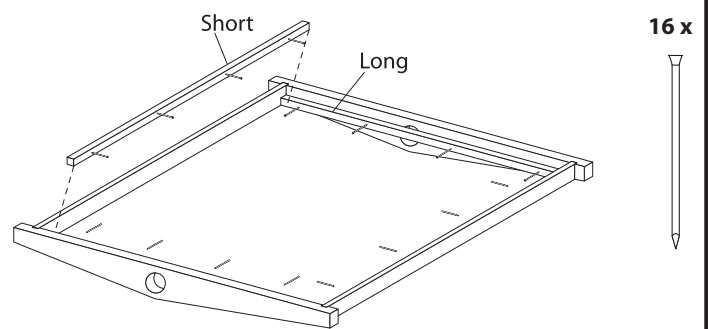

2 Turn roof over and position inner end strips (longer). Nail to ends using 4 x 25 mm pins. Position inner side strips (shorter). Nail to sides using 4 x 25 mm pins.

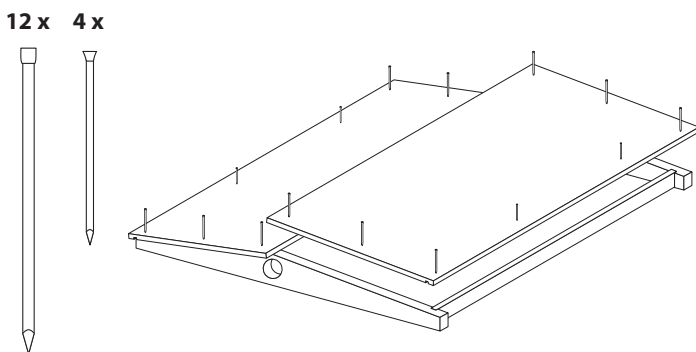

3 Position roof panels as shown (overhang equally at each end) and nail to end boards using 12 x 40 mm lost head nails. Nail to sides using 4 x 25 mm pins.

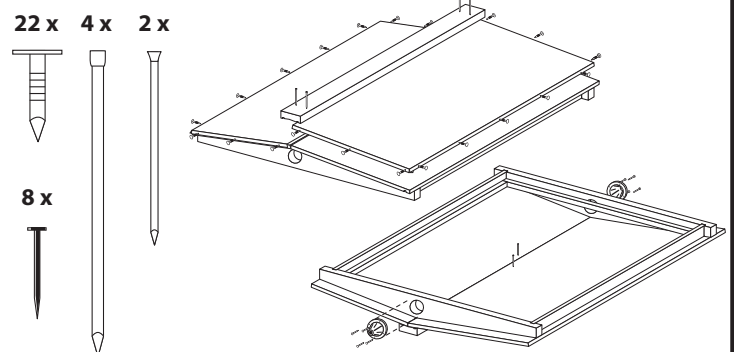

4 Turn roof over, place metal covers over roof and nail to roof edges using 22 x 12 mm round head nails. Position apex cover strip as shown and nail to roof end boards using 4 x 40 mm lost head nails. Turn roof over and nail through roof panels into apex cover strip using 2 x 25 mm pins. Position vent covers over vent holes and nail in place using 8 x 12 mm black japanned round head tacks.

Old Road, Maisemore, Gloucester, GL2 8HT Tel: 01452 700289 Fax: 01452 700196 email: sales@bees-online.co.uk www.bees-online.co.uk www.honey-online.co.uk

Assembly Instructions - WBC Lift



MAISEMORE APIARIES

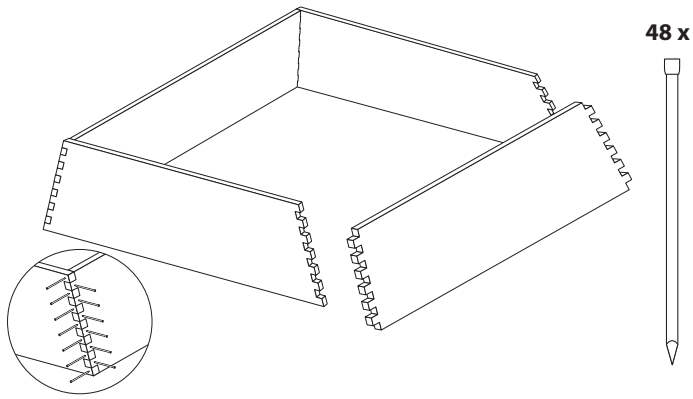

1 Fit sides together as shown. Nail through each dovetail with a 40 mm lost head nail as shown in diagram, 12 per corner. Check assembly is square.

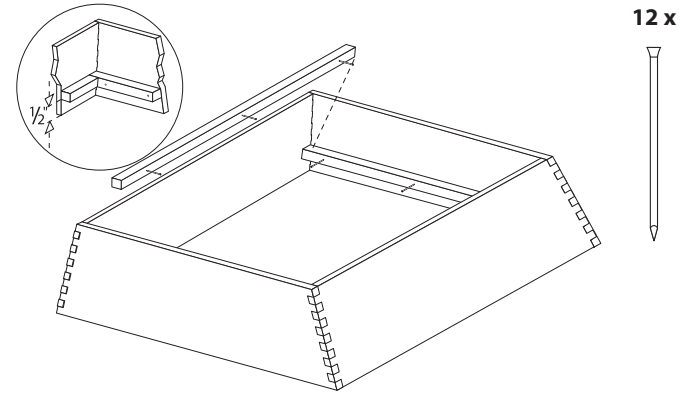

2 Position lift support battens 1/2" up from lower edge as shown and nail each one with 3 x 25 mm pins.

Porch where fitted

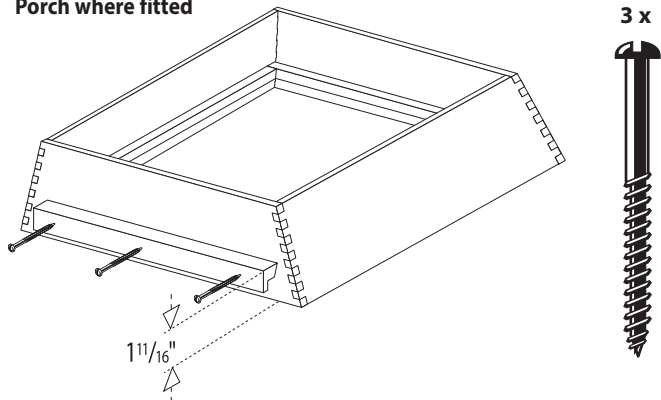

3 Position porch base, correct way up as shown, with top edge 1¹/₁₆ inches above lower edge of lift. Fix in place with 3 x 40 mm black japanned screws.

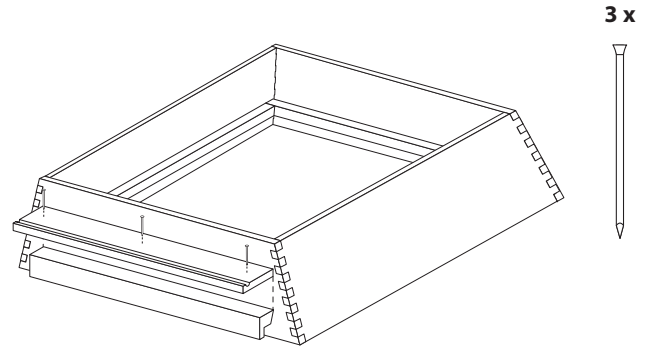

4 Place porch roof with drip groove uppermost and outwards onto porch base and nail with 3 x 25 mm pins.

Old Road, Maisemore, Gloucester, GL2 8HT Tel: 01452 700289 Fax: 01452 700196 email: sales@bees-online.co.uk www.bees-online.co.uk www.honey-online.co.uk

Assembly Instructions - WBC Lift



MAISEMORE APIARIES

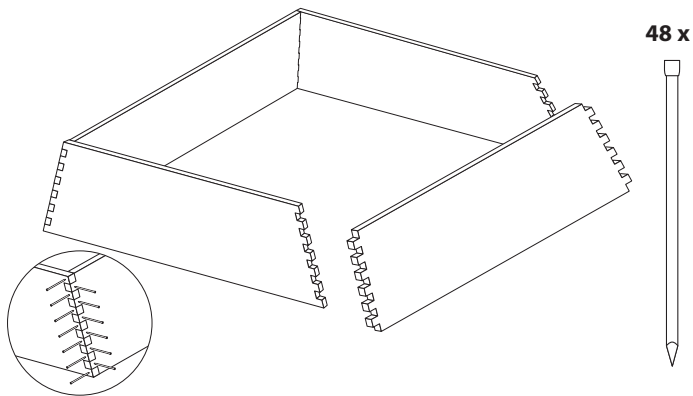

1 Fit sides together as shown. Nail through each dovetail with a 40 mm lost head nail as shown in diagram, 12 per corner. Check assembly is square.

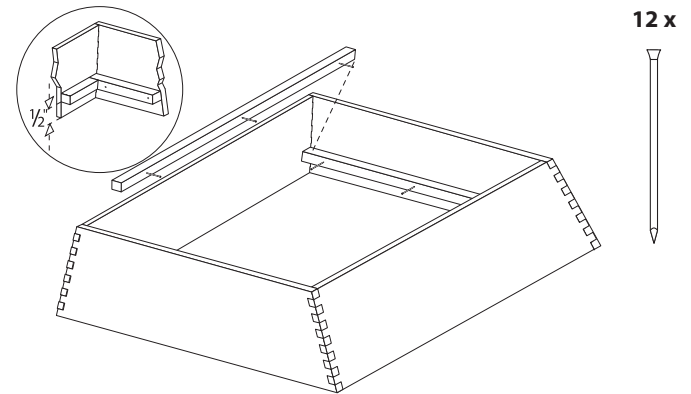

2 Position lift support battens 1/2" up from lower edge as shown and nail each one with 3 x 25 mm pins.

Porch where fitted

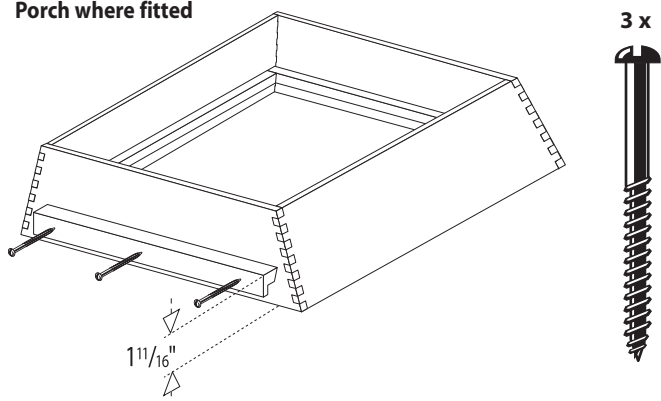

3 Position porch base, correct way up as shown, with top edge 1¹/₁₆ inches above lower edge of lift. Fix in place with 3 x 40 mm black japanned screws.

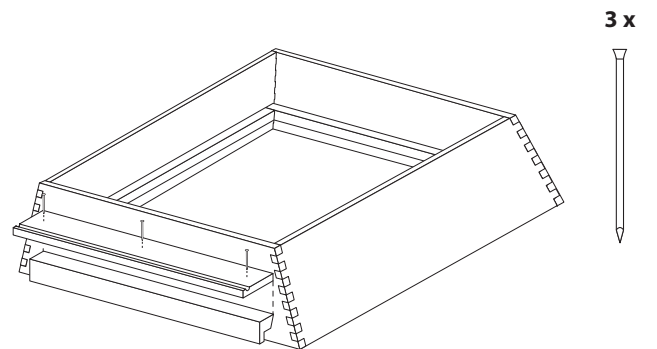

4 Place porch roof with drip groove uppermost and outwards onto porch base and nail with 3 x 25 mm pins.

Old Road, Maisemore, Gloucester, GL2 8HT Tel: 01452 700289 Fax: 01452 700196 email: sales@bees-online.co.uk www.bees-online.co.uk www.honey-online.co.uk